

7. 3 bottle rack Plus a shelf (Shelf max load – 20Kg.)

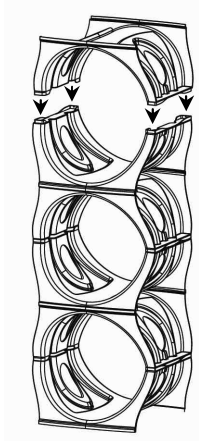

7.1

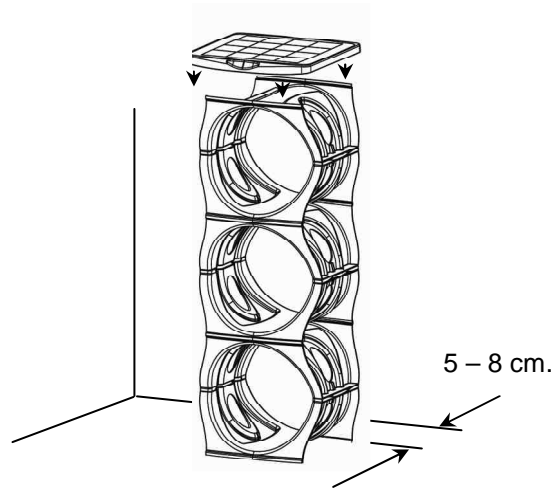

7.2



CONFIGURATIONS & COMPONENTS ⁷				
	X 3	X 4	X 5	X 6
		X 1		X 1
	X 2	X 2	X 2	X 2

Patent pending

Modular water bottle rack



Contact us : 14, avenue Lavoisier - 64140 LONS - FRANCE
 Telephone : 00 33 559 92 43 43 - Fax : 00 33 559 40 18 55
 Email : info@op-crate.com - www.op-crate.com

1. Add U-shape rubber strips

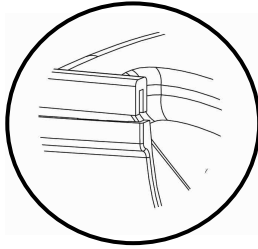
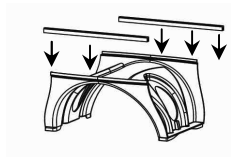

2. Place the first unit

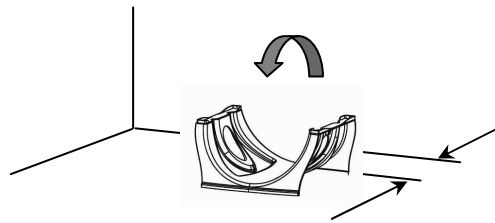

5 – 8 cm.

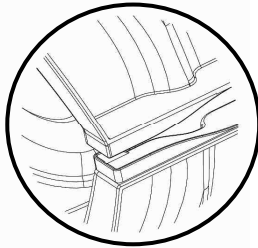

3. Place an addition unit

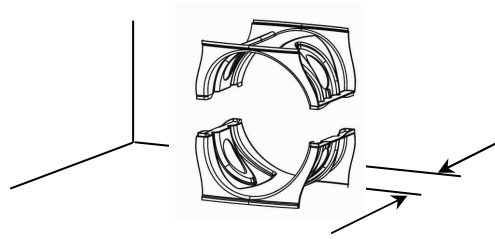

5 – 8 cm.

4. 2 bottle rack configuration

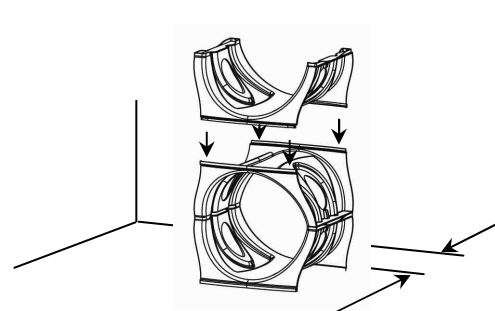

5 – 8 cm.

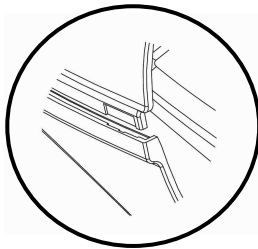

5. 2 bottle rack Plus a shelf (Shelf max load – 20Kg.)

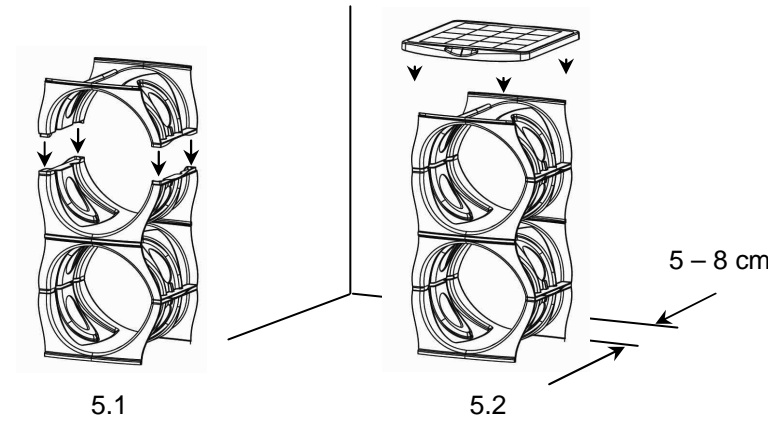

5.1

5.2

5 – 8 cm

6. 3 bottle rack

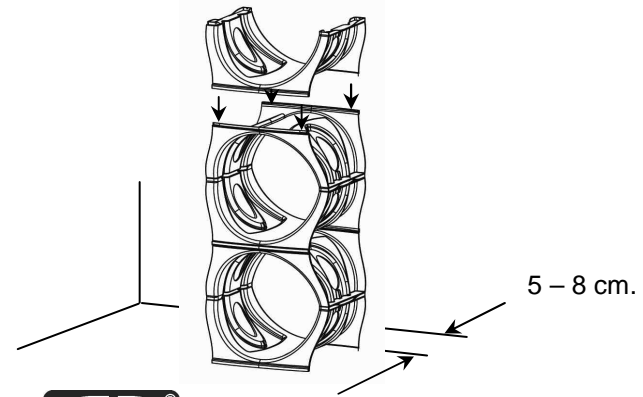

5 – 8 cm.



We recommend stacking no more than 3 full bottles in the same pile